

# TECHNICAL DATA SHEET

**VALSIR® WASTE SYSTEMS**

**SILERE  
VBF**



***valsir***®  
QUALITY FOR PLUMBING



# SILERE

## VBF - VENTILATION BRANCH FITTING

---

### Charateristics

---

Code:	VS0273XXXXXX
Raw material:	Silere (PP + Minerals)
Seal material	SBR
Vertical connection D.:	110 mm
Max. number of connections D. 110 mm:	3
Max. number of connections D. 75 mm:	3
Max temperature of waste water	80° C (continuous) 95° C (intermittent)
Standard achievable flow rate:	8.7 l/s (*)

(\*) The achievable flow rate could be increased following verification with Valsir Technical Department.

---

### DESCRIPTION:

Valsir Silere is an acoustic push-fit waste system with a performance of 6 dB(A) at 2 l/s as per EN14366. The system is manufactured in Italy and certified by leading international bodies, in compliance with EN 1451-1, suitable for the drainage of fluids, and ISO TR 10358.

Valsir VBF is part of Valsir Silere single stack system and it is made up of an acoustic blend of polypropylene with mineral loads.

Valsir Silere range is completely halogen free.

Valsir VBF fitting has 6 horizontal branch connections: 3 x DN 100 (OD 110 mm) upper push-fit connections for sanitary fixtures such as urinals, WCs, washbasins, bidets, showers, bathtubs, sinks or any other sanitary fixture and 3 x DN 70 (OD 75 mm) lower push-fit connections for any sanitary fixture.

Valsir VBF fitting is able to improve the ventilation performance of the waste and drainage system, increasing the flow rate is compared to other traditional solutions.

The standard achievable flow rate is 8.7 l/s.

Every Valsir VBF fitting can collect up to 25 DU, as per EN12056.





# SILERE

## VBF - VENTILATION BRANCH FITTING

Size:

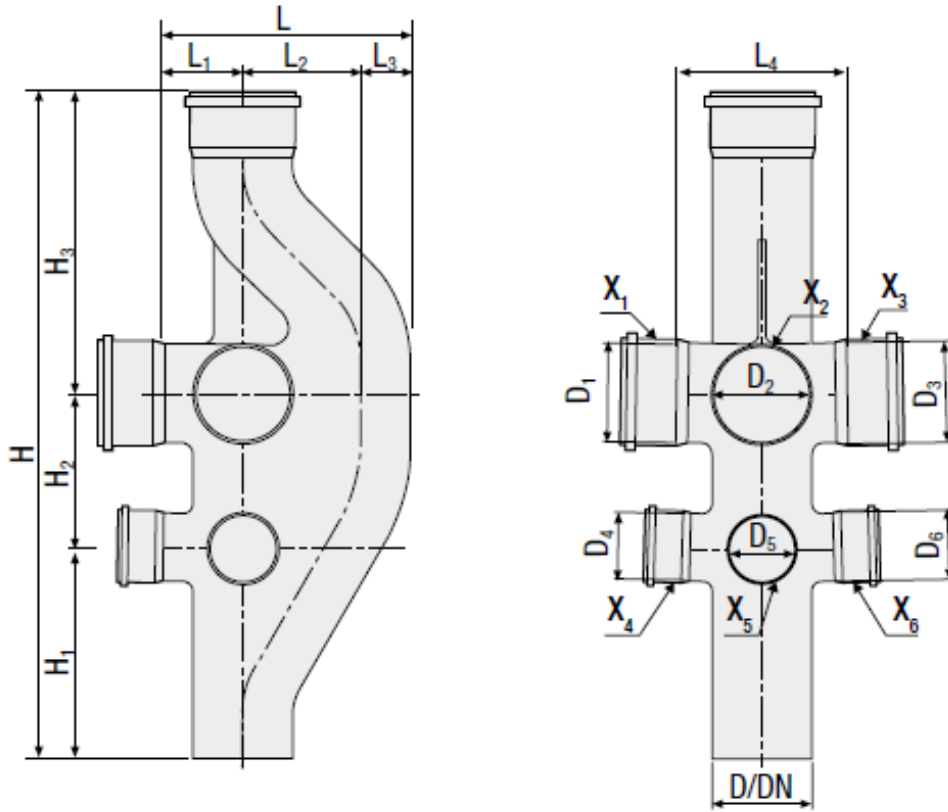

COD.	D	DN	D <sub>1</sub> /D <sub>2</sub> /D <sub>3</sub>	D <sub>4</sub> /D <sub>5</sub> /D <sub>6</sub>	L	L <sub>1</sub>	L <sub>2</sub>	L <sub>3</sub>	L <sub>4</sub>	H	H <sub>1</sub>	H <sub>2</sub>	H <sub>3</sub>
VS0273X <sub>1</sub> X <sub>2</sub> X <sub>3</sub> X <sub>4</sub> X <sub>5</sub> X <sub>6</sub> *	110	100	110	75	355	175	130	50	355	760	230	170	360

### Approvals:

The approvals of Valsir® waste systems are available on the website: [www.valsir.com](http://www.valsir.com)

# PLUMBING

WASTE SYSTEMS



SUPPLY SYSTEMS



GAS SYSTEMS



FLUSH SYSTEMS



BATHROOM SYSTEMS



TRAPS



RADIANT SYSTEMS



DRAINAGE SYSTEMS



HRV SYSTEM



ACADEMY



SEWER SYSTEMS



WATER TREATMENT



# BUILDING

**valsir**<sup>®</sup>  
QUALITY FOR PLUMBING

**VALSIR S.p.A.**  
Località Merlaro, 2  
25078 Vestone (BS) - Italy  
Tel. +39 0365 877.011  
Fax +39 0365 81.268  
e-mail: [valsir@valsir.it](mailto:valsir@valsir.it)

**[www.valsir.com](http://www.valsir.com)**

Soggetta all'attività di direzione e coordinamento ex art. 2497 bis C.C. da parte di Fondital Group S.p.A. - Codice Fiscale 02075160172