

BIS RapidRail® Rail Suspension Bracket

fixing of rail to stud bolt

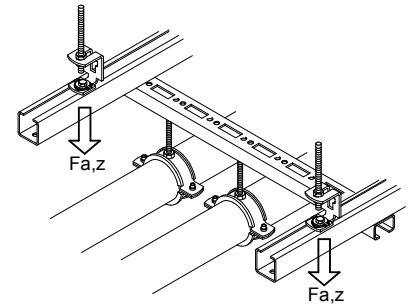

Features and Benefits

- connector with pre-assembled BIS RapidRail® Slide nut(s)
- suitable for WM0, 1, 15, 2, 30, 35
- ready-to-use pre-assembled for a quick fixing, and retains assembly in place before final tightening
- with pre-assembled BIS RapidRail® Sliding nut(s) for a quick fixing, and retains assembly in place before final tightening
- stud bolt with upturned nut hooked in easily because of cross-shaped hole
- material: metal parts made of steel 1.0332; spring(s) made of POM (polyoxymethylene), green
- zinc plated



RAL-GZ 655/D
Cert.Nr. 2012-09

Part No.	For Rail	T (Nm)	Fa,z (N)	Fa,x (N)	RAL	Pack 1
679 3 008	WM0 - 35	15	1.600	79	RAL ¹	50

RAL¹ = tested, certified and externally monitored according to RAL-GZ 655/D in combination with Rail WM1, 2, 15 and 30.

For detailed technical information about our RAL marked products, please see the RAL datasheet in our webcatalogue: www.walraven.com/int/catalogue/.

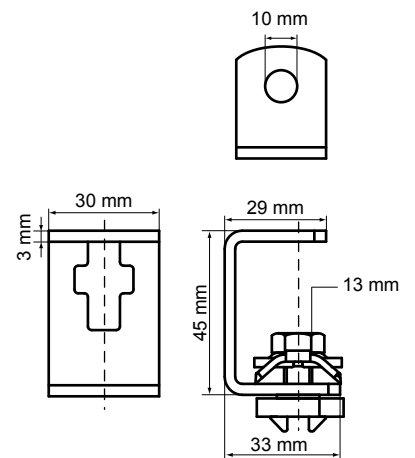

Complementary

BIS RapidRail® Fixing Rail

179